

Web Tension Measurement Unit

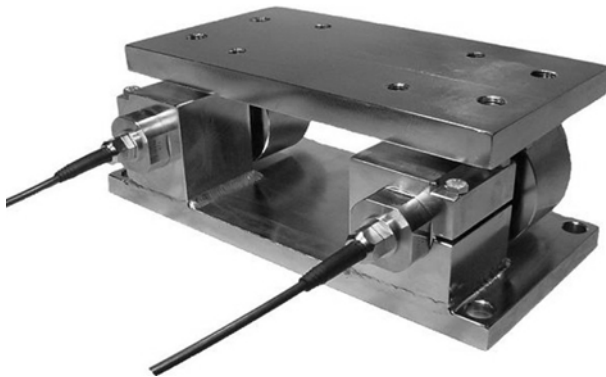

FEATURES

- Measure exact resultant web tension force
- Superior accuracy for heavy rolls with small wrap angles
- Low profile - minimal change in line profile when retrofitting existing equipment
- Units customized to fit existing applications - no reconstruction required

OPTIONAL FEATURES

- High temperature units - functional to 100°C
- Special units designed to meet any application need

DESCRIPTION

FMU applications include all zones on paper processing machines and steel mill strip tension equipment.

Each FMU consists of two precision load cells, a load plate that carries the pillow block, and a base plate that mounts to the machine support. The unique design of the FMU allows measurement of the resultant web tension force without the need to mount the entire assembly on a sloped support. Because the load cells are cylindrical, they can be rotated to measure in the direction of the exact resultant force.

Measuring the resultant force rather than a vertical or horizontal component assures the highest possible accuracy and eliminates wrap angle restrictions.

Tension signals from the FMU feed directly into a web tension transmitter which provides load cell excitation and a communication interface for the host PLC/DCS system.

Whether you are using standard products or customized solutions, our highly skilled system engineers, service technicians, and flexible production sites can meet your demands with a high level of professionalism.

APPLICATIONS

- Paper machines
- Steel strip tension equipment
- Mining conveyors
- Felts, dryers, calenders, coaters, and laminators
- Winders and rewinders

CONFIGURATION

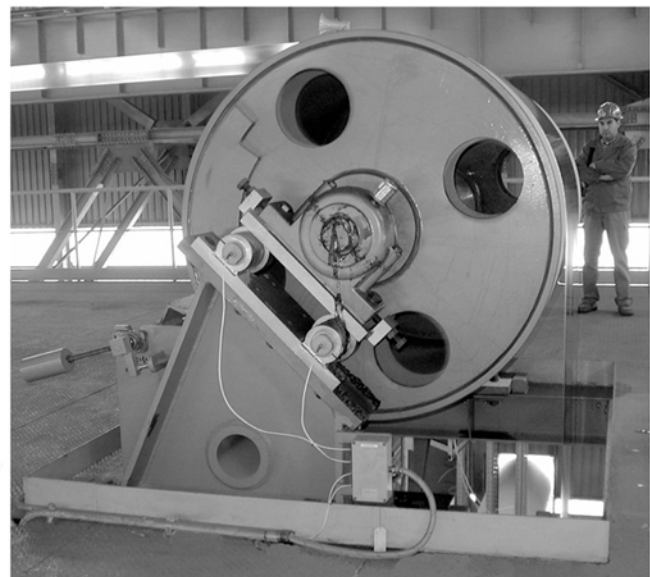
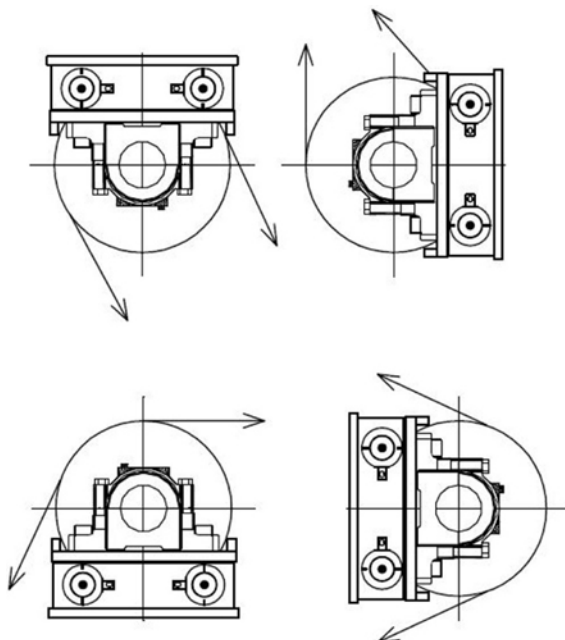

OUTLINE DIMENSIONS

Typical dimensions FMU-1:

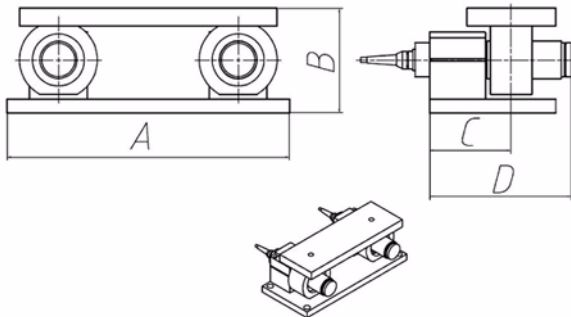

Typical dimensions FMU-5:

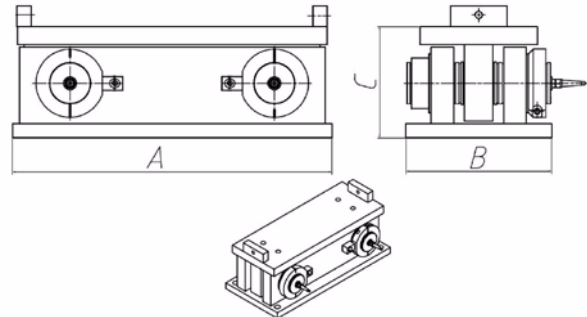

CAPACITY	A (mm)	B (mm)	C (mm)	D (mm)
2, 4, 10kN	320	110	94.5	150
20, 40, 60kN	380	140	110	190.5
100kN	570	175	157	268
200kN	640	219	167	292.5

CAPACITY	A (mm)	B (mm)	C (mm)
100, 200kN	480	260	205
400kN	680	310	236

SPECIFICATIONS

TYPICAL TECHNICAL DATA	FMU-1	FMU-5	UNIT
Capacity	2 to 200	100 to 400 (800*)	kN
Accuracy error / Repeatability	Better than 0.1%	Better than 0.1%	of R.O.
Accuracy error / Repeatability (with one dummy load cell)	Better than 0.5%	Better than 0.5%	of R.O.
Input voltage recommended	10	10	V DC or AC
Input voltage maximum	18	18	V DC or AC
Rated output (R.O.)	2	2	mV/V
Temperature range (more on demand)	-40 to +80 (100*)	-40 to +80 (100*)	°C
Electrical connection	Shielded four conductor cable or connector	Shielded four conductor cable or connector	
Material	Yellow chromate or stainless steel	Yellow chromate or stainless steel	

Nobel engineers are capable of customizing FMU transducers to meet all application needs.

* option available